

Jordan 1000 kwh battery

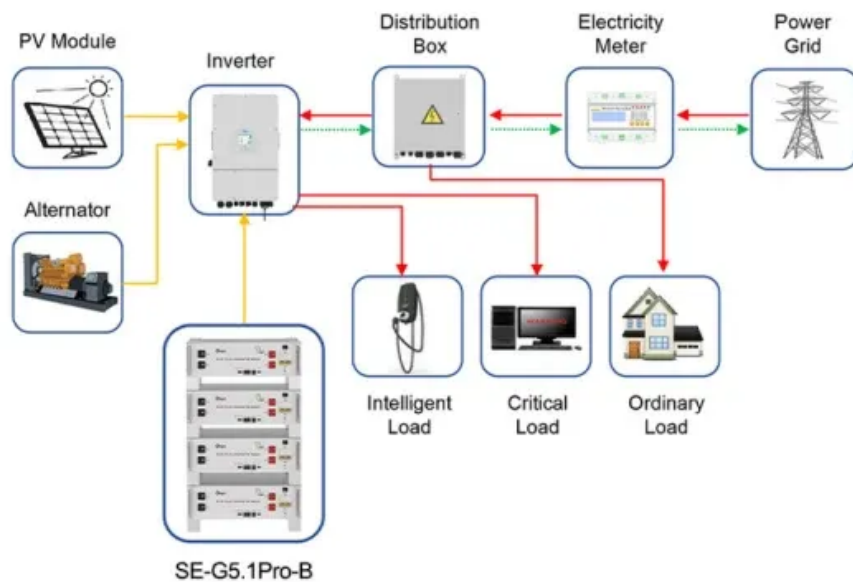

Application scenarios of energy storage battery products





Jordan 1000 kwh battery



Marktübersicht große Batteriespeicher

Unsere aktualisierte Marktübersicht der Gewerbe- und Netzspeicher (Stand Februar 2024) bietet einen Überblick über Hersteller von Komponenten, Systemintegratoren, Betriebsführer und EPCs mit ihren Angeboten für Batteriespeicher in Europa und weltweit ab Kapazitäten von 30 Kilowattstunden aufwärts. In der Übersicht sind 52 Anbieter mit mehr als 300 Produkten und ...

A Stand-Alone Hybrid Photovoltaic, Fuel Cell, and Battery ...

Qandil et al. [26] examined the feasibility of using a hybrid PV, fuel cell, and battery system to power various loads in Jordan's Al-Zarqa governorate. Solar energy potentials in the



Revolutionizing the Future: 1000 kWh Batteries - jordanbreeding

The introduction of 1000 kWh batteries marks a significant milestone in our journey towards a sustainable and energy-efficient future. These powerful storage solutions ...

Feasibility and optimal sizing analysis of hybrid renewable energy



Aiad et al. [23] have proposed the optimal selection of Hybrid PV/Wind systems for Jordanian Conditions in Amman, they found that the best system size was 258.5 kW wind turbines, 170.25 kW PV, and 604.66 kWh battery bank, with a payback period of 6.93 years and LCOE of 0.0624 USD\$/kWh.



ENECHANGE and Loop announce investment in Al Badiya, the ...

This project was approved as one of government-led tenders for renewable energy generation in Jordan, and Tesla storage batteries (capacity 12,600 kWh) are installed on the site. In Jordan, the renewable energy connection capacity to the power system is limited by the grid capacity, meaning high solar opportunities are not fully utilized.

Sizing, economic, and reliability analysis of photovoltaics and ...

A Jordan campsite was used as a case study to assess and compare the performance of PV-battery storage and PV-hydrogen storage systems from economic and reliability perspectives. The results show that hydrogen storage was more economical for a 100% renewable energy system.



Sizing, economic, and reliability analysis of photovoltaics and ...

A Jordan campsite was used as a case study to assess and compare the performance of PV-battery storage and PV-hydrogen storage systems from economic and ...



CONTAINERIZED ENERGY STORAGE SYSTEM ECO ...

It adopts standardized general-purpose energy storage battery module with building block design and flexible power capacity configuration, which can meet different functional requirements

...



Feasibility and optimal sizing analysis of hybrid renewable energy

Aiad et al. [23] have proposed the optimal selection of Hybrid PV/Wind systems for Jordanian Conditions in Amman, they found that the best system size was 258.5 kW wind ...



1MW Battery Energy Storage System

The MEGATRON 1MW Battery Energy Storage System (AC Coupled) is an essential component and a critical supporting technology for smart grid and renewable energy (wind and solar). The

...

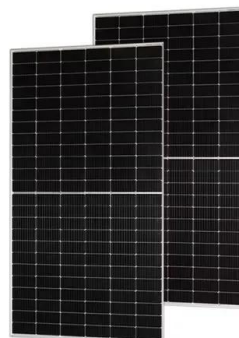



1000 kWh Battery Wholesale , Prices, Size, Weight of 1000 kWh ...

Download the datasheet of 1000 kWh energy storage system. Check out 1000 kWh battery packs' available brands, prices, sizes, weights, warranty, and voltage.

A Stand-Alone Hybrid Photovoltaic, Fuel Cell, and Battery System: ...

Qandil et al. [26] examined the feasibility of using a hybrid PV, fuel cell, and battery system to power various loads in Jordan's Al-Zarqa governorate. Solar energy ...



ENECHANGE and Loop announce investment in Al Badiya, the ...

This project was approved as one of government-led tenders for renewable energy generation in Jordan, and Tesla storage batteries (capacity 12,600 kWh) are installed on the site. In Jordan, ...



CONTAINERIZED ENERGY STORAGE SYSTEM ECO ...

It adopts standardized general-purpose energy storage battery module with building block design and flexible power capacity configuration, which can meet different functional requirements such as peak regulation and frequency modulation, wind and solar energy absorption, power capacity expansion, peak shaving and valley filling, emergency power





**2MW / 5MWh
Customizable**

Marktübersicht große Batteriespeicher

Unsere aktualisierte Marktübersicht der Gewerbe- und Netzspeicher (Stand Februar 2024) bietet einen Überblick über Hersteller von Komponenten, Systemintegratoren, Betriebsführer und ...

1MW Battery Energy Storage System

The MEGATRON 1MW Battery Energy Storage System (AC Coupled) is an essential component and a critical supporting technology for smart grid and renewable energy (wind and solar). The MEG-1000 provides the ancillary service at the front-of-the-meter such as renewable energy moving average, frequency regulation, backup, black start and demand response.



Revolutionizing the Future: 1000 kWh Batteries - jordanbreeding

The introduction of 1000 kWh batteries marks a significant milestone in our journey towards a sustainable and energy-efficient future. These powerful storage solutions not only revolutionize the way we consume electricity but also pave the way for cleaner transportation systems and industry-specific applications.

Contact Us

For catalog requests, pricing, or partnerships, please visit:
<https://www.fundacja64.pl>