

Saint Helena zanussi solar

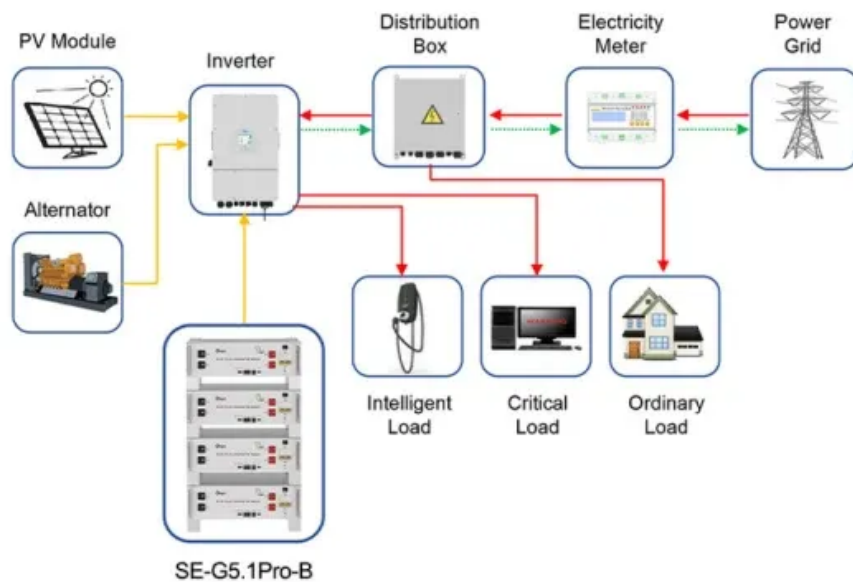

Application scenarios of energy storage battery products





Saint Helena zanussi solar

Our current renewable energy sources



You can access data about the energy generated from the 'farm' at (click on 'Publicly available PV systems' then find St Helena). PASH Global. In April 2018 the Government of St Helena announced it had chosen a supplier to provide a renewable energy solution for St Helena, aiming for 100% renewable electricity by 2027.

ENERGY DELIVERY PLAN

This document sets out a plan for phased delivery of improvements in the energy sector on St Helena, particularly to support plans for energy transition on St Helena. The Energy Delivery Plan recognises that globally countries are making every effort to reduce



Zanussi Solar

We are now a year after the installation of 15 solar panels by Zanussi Solar, we were told by the installer to check the generating figures over the next year then compare with those given by salesman. We were told that we could claim money back if they were significantly different 1957kWh generated, quoted 4570kWh that would be generated.

PPA signed for solar-wind-storage microgrid on Saint Helena

The agreement with Connect Saint Helena Ltd



includes a microgrid for the South Atlantic island that combines a 568 kWp/500 kW solar farm; a three-turbine, 2.7 MW wind farm; and a 3.2 MWh/3.5



Solar Power

The electricity generation data for all our solar sites is publicly accessible on line. To find out how to access this information, please see the article Sunnyportal - Solar Energy. Below is a graph showing the amount of electricity (kWh) generated by means of our solar systems since Connect's start in April 2013.

Electricity Generation

Connect Saint Helena Ltd generates electricity in 3 ways: Diesel Powered Generators at the Power Station in Ruperts; Wind; Solar; Electricity from Diesel At present approximately 75% of the islands electricity is generated from burning fossil fuel (diesel). We have 4 generators which have a total capacity of 5,400kW.

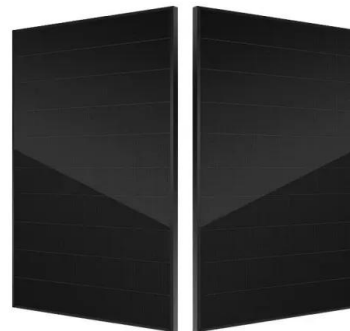

PASH GLOBAL SIGNS A 25 YEAR POWER DEAL TO BUILD HYBRID ...

The project will deliver the lowest cost electricity to Saint Helena and reduce the islands reliance on imported diesel, switching entirely to renewable energy to meet majority of the electricity needs, making Saint Helena one of the "greenest" ...



St Helena

Location: St. Helena; Installed capacity: Solar PV (0.5MWp), Wind (3MW), Battery (3.5MWh) Hybrid Solution; Status: 90% of development activity is completed; Technology: hybrid system comprising of Solar PV, Wind and BESS; CO2 emission reductions per year: 5,110 MtCO2 saved annually . Articles, News and Press Releases



RENEWABLE ENERGY PROCUREMENT PROJECT PASH TO

PASH's bid provides for 1.6MWh of battery storage, 1MW of wind turbines located at Deadwood Plain, subject to Environmental Impact Assessment, Planning Approval and approval from Air Safety Support International (ASSI), and 0.5MW of solar panels to be located on land already owned by Connect adjacent to the existing solar site at the Rifle

Connect Saint Helena Ltd Signs Contract With PASH To Meet ...

Connect Saint Helena Ltd (Connect) has today signed a Power Purchase Agreement with PASH Global to provide wind turbine, solar power and battery storage capacity to St Helena, significantly increasing the amount of renewable energy capacity on the Island and resulting in the majority of the Island's energy needs being met by renewable sources.



Solar Power

The electricity generation data for all our solar sites is publicly accessible on line. To find out how to access this information, please see the article Sunnyportal - Solar Energy. Below is a graph showing the amount of electricity (kWh) ...



Lithium Solar Generator: S150



Contact Us

For catalog requests, pricing, or partnerships, please visit:
<https://www.fundacja64.pl>